



# Australian Model Railway Association

## Free form module standard

**Version 1.1**  
**June 2009**

### **Aim**

The aim of this standard is to define the mechanical and electrical interface for single track free form modules.

### **Introduction**

Portable model railways are built in sections called modules. The idea of different people building separate modules and joining them together to make a large model railway has seen the development of many incompatible club standards. In 1989 the friendship association of European model railroaders was formed (FREMO) and developed a number of single track free form style module standards. Unlike the earlier module systems the FREMO concept allowed for maximum flexibility in module design and has been adapted by various groups around the world.

### **Module Design**

Modules can be constructed of any suitable material as long as it supports the track work and scenery with sufficient strength and stiffness. The shape, width, length and depth of the module can vary except at the module end plate. Modules can consist of separate sections allowing greater design flexibility and ease of transport. The section endplates can be of any shape and size and use any method of joining which results in reliable operation. Each module shall be self supported. The support legs shall have a minimum of 20mm adjustment.

### **Module Clamping**

Modules are joined together using clamps or alternatively using nuts, bolts and flat washers through holes provided in the module endplates. When using bolts to clamp the module end plates, flat washers are to be used between the clamping bolt, endplate and nut. The maximum bolt diameter to be used is 6mm.

### **Track**

Track work shall comply with relevant AMRA standards. The track height shall be 1200mm measured from the top of the rail head to the floor. The track shall be centered, square and straight at the endplate for a minimum distance of half the maximum length vehicle used. The rail shall be set back between 0.1mm and 0.5mm from the outer face of the endplate. The rail at the module endplate shall be firmly attached by either soldering to screws or copper clad sleepers. All crossing V's and K's (Frogs) shall be of metal construction.

**Note:** Rail joiners or bridging rails are not to be used at the interface between modules.



# Australian Model Railway Association Free form module standard

Version 1.1  
June 2009

## Module endplate

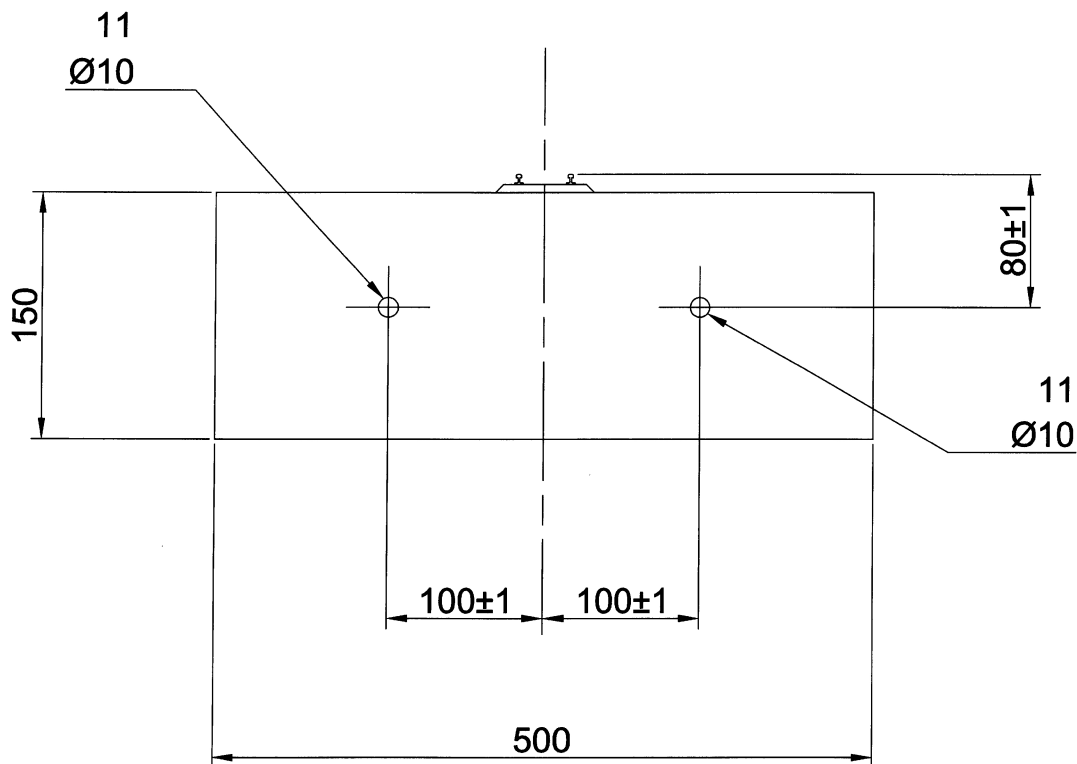

All dimensions: mm  
Tolerance unless otherwise stated: +/- 6mm  
Minimum end plate thickness: 17mm  
End plate material: Plywood

**Note:** MDF or dimensional timbers are not to be used for the endplate. Metal or composites of demonstrated stiffness and strength can be substituted as the end board material



# Australian Model Railway Association

## Free form module standard

Version 1.1  
June 2009

## DCC Wiring

### Track Power Buss

The power buss uses 2 wires to carry track power between modules. The power buss shall use a minimum 1.6mm diameter (14 AWG) copper wire or multiple strand cable with a minimum 2mm<sup>2</sup> copper conductor cross sectional area. It is recommended the track power buss be twisted around each other to decrease electrical interference. At the endplate, the power buss cable shall extend at least 300mm from the endplate and be terminated with 2 red PP30 Anderson Power Pole connectors joined vertically, tabs down. The top conductor shall be electrically connected via the track feeds to the right hand rail when looking at the end plate. The bottom conductor shall be electrically connected via the track feeds to the left hand rail when looking at the end plate.

Note: No accessories shall be powered from the track power buss

### Track Feeds

The track feed wires shall use a minimum 0.5mm diameter (24 AWG) copper wire or multiple strand cable with a minimum 0.22mm<sup>2</sup> copper conductor cross sectional area. Each rail shall have its own track feed wire including crossing V's and K's.

### DCC Command Buss

The DCC command buss shall consist of Category 5e (Cat5e), 8 core twisted pair cable designed for crimp connection to 8p8c (RJ45) modular plugs and sockets. A 8p8c female socket shall be mounted close to the endplate and clear of the area used for clamping. All plugs and sockets shall have straight through wiring. A cable at least 500mm long with 8p8c male plugs using Cat5 cable with straight though wiring shall be used to connect the DCC command buss between modules.



# Australian Model Railway Association

## Free form module standard

**Version 1.1**  
**June 2009**

### **Accessory Buss**

The accessory buss uses 2 wires to carry track power between modules. The accessory bus shall supply 16 Volts 5 Amps AC and shall use a minimum 1.3mm diameter (16AWG) copper wire or multiple strand cable with a minimum 1.3mm<sup>2</sup> copper conductor cross sectional area. At the endplate, the accessory buss cable shall extend at least 300mm from the endplate and be terminated with 2 black PP30 Anderson Power Pole connectors joined horizontally.

### **Overload protection**

Each module shall provide overload protection of 3.5A or less between

1. The power buss and track feeds.
2. The accessory buss and accessory feeds.